



Operating Instructions and Parts Manual Drum Sander

Model: 10-20 Plus



JET
427 New Sanford Road
LaVergne, Tennessee 37086
Ph.: 800-274-6848
www.jettools.com

Part No. M-628900
Revision C3 02/2014
Copyright © 2014 JET

Warranty and Service

JET warrants every product it sells against manufacturers' defects. If one of our tools needs service or repair, please contact Technical Service by calling 1-800-274-6846, 8AM to 5PM CST, Monday through Friday.

Warranty Period

The general warranty lasts for the time period specified in the literature included with your product or on the official JET branded website.

- JET products carry a limited warranty which varies in duration based upon the product. (See chart below)
- Accessories carry a limited warranty of one year from the date of receipt.
- Consumable items are defined as expendable parts or accessories expected to become inoperable within a reasonable amount of use and are covered by a 90 day limited warranty against manufacturer's defects.

Who is Covered

This warranty covers only the initial purchaser of the product from the date of delivery.

What is Covered

This warranty covers any defects in workmanship or materials subject to the limitations stated below. This warranty does not cover failures due directly or indirectly to misuse, abuse, negligence or accidents, normal wear-and-tear, improper repair, alterations or lack of maintenance.

Warranty Limitations

Woodworking products with a Five Year Warranty that are used for commercial or industrial purposes default to a Two Year Warranty. Please contact Technical Service at 1-800-274-6846 for further clarification.

How to Get Technical Support

Please contact Technical Service by calling 1-800-274-6846. **Please note that you will be asked to provide proof of initial purchase when calling.** If a product requires further inspection, the Technical Service representative will explain and assist with any additional action needed. JET has Authorized Service Centers located throughout the United States. For the name of an Authorized Service Center in your area call 1-800-274-6846 or use the Service Center Locator on the JET website.

More Information

JET is constantly adding new products. For complete, up-to-date product information, check with your local distributor or visit the JET website.

How State Law Applies

This warranty gives you specific legal rights, subject to applicable state law.

Limitations on This Warranty

JET LIMITS ALL IMPLIED WARRANTIES TO THE PERIOD OF THE LIMITED WARRANTY FOR EACH PRODUCT. EXCEPT AS STATED HEREIN, ANY IMPLIED WARRANTIES OF MERCHANTABILITY AND FITNESS FOR A PARTICULAR PURPOSE ARE EXCLUDED. SOME STATES DO NOT ALLOW LIMITATIONS ON HOW LONG AN IMPLIED WARRANTY LASTS, SO THE ABOVE LIMITATION MAY NOT APPLY TO YOU.

JET SHALL IN NO EVENT BE LIABLE FOR DEATH, INJURIES TO PERSONS OR PROPERTY, OR FOR INCIDENTAL, CONTINGENT, SPECIAL, OR CONSEQUENTIAL DAMAGES ARISING FROM THE USE OF OUR PRODUCTS. SOME STATES DO NOT ALLOW THE EXCLUSION OR LIMITATION OF INCIDENTAL OR CONSEQUENTIAL DAMAGES, SO THE ABOVE LIMITATION OR EXCLUSION MAY NOT APPLY TO YOU.

JET sells through distributors only. The specifications listed in JET printed materials and on official JET website are given as general information and are not binding. JET reserves the right to effect at any time, without prior notice, those alterations to parts, fittings, and accessory equipment which they may deem necessary for any reason whatsoever. JET® branded products are not sold in Canada by JPW Industries, Inc.

Product Listing with Warranty Period

90 Days – Parts; Consumable items; Light-Duty Air Tools
1 Year – Motors; Machine Accessories; Heavy-Duty Air Tools; Pro-Duty Air Tools
2 Year – Metalworking Machinery; Electric Hoists, Electric Hoist Accessories; Woodworking Machinery used for industrial or commercial purposes
5 Year – Woodworking Machinery
Limited Lifetime – JET Parallel clamps; VOLT Series Electric Hoists; Manual Hoists; Manual Hoist Accessories; Shop Tools; Warehouse & Dock products; Hand Tools

NOTE: JET is a division of JPW Industries, Inc. References in this document to JET also apply to JPW Industries, Inc., or any of its successors in interest to the JET brand.

Table of Contents

Warranty and Service	2
Table of Contents	3
Warnings	4
Introduction	6
Specifications	6
Unpacking	7
Contents of the Shipping Container	7
Tools Required for Assembly	7
Assembly	7
10-20 Plus Sander	7
Stand	7
Installing the Trackers™	8
Electrical	9
Electrical Requirements	9
Electrical Connections	9
Extension Cords	9
Controls	10
On/Off Switch	10
Adjustments	11
Drum Height Control	11
Conveyor Belt Tension	11
Conveyor Belt Tracking	11
Drum Alignment	12
Wrapping Abrasive Strips	13
Using the TUF Tool™	14
Connecting Sander to a Dust Collector	15
Setting the Depth Gauge	15
Setting the Depth of Cut	15
Establishing the Proper Drum Height	15
Abrasives	16
Overview	16
Selecting Drum Abrasives	16
Selecting Abrasive Grits	16
Cleaning Abrasive Strips	16
Stretching Abrasive Life	16
Stock Feeding Angle	17
Multiple-Piece Sanding Runs	17
Edge Sanding	17
Sanding Imperfect Stock	17
Face Frames and Raised Panel Doors	17
Maintenance	17
Conveyor Belt Replacement	18
Tension Roller Alignment	18
Tension Roller Pressure Adjustment	18
Drum Height Control Adjustment	18
Troubleshooting	19
Parts	20
Parts List	20
Assembly Drawing	22
Optional Accessories	23
JET 10-20 Sander Accessories	23
JET 10-20 Abrasives	23
Wiring Diagram	23
Replacement Parts	23

Warnings

1. Read and understand the entire owner's manual before attempting assembly or operation.
2. Read and understand the warnings posted on the machine and in this manual. Failure to comply with all of these warnings may cause serious injury.
3. Replace the warning labels if they become obscured or removed.
4. This drum sander is designed and intended for use by properly trained and experienced personnel only. If you are not familiar with the proper and safe operation of a drum sander, do not use until proper training and knowledge have been obtained.
5. Do not use this machine for other than its intended use. If used for other purposes, JET disclaims any real or implied warranty and holds itself harmless from any injury that may result from that use.
6. Always wear approved safety glasses/face shields while using this machine. Everyday eyeglasses only have impact resistant lenses; they are not safety glasses.
7. Before operating this machine, remove tie, rings, watches and other jewelry, and roll sleeves up past the elbows. Remove all loose clothing and confine long hair. Non-slip footwear is recommended.
8. Wear ear protectors (plugs or muffs) during extended periods of operation.
9. This drum sander is to be used with wood and wood products only. Use of this drum sander and a dust collector with metal products is a potential fire hazard.
10. Some dust created by power sanding, sawing, grinding, drilling and other construction activities contain chemicals known to cause cancer, birth defects or other reproductive harm. Some examples of these chemicals are:
 - Lead from lead based paint.
 - Crystalline silica from bricks, cement and other masonry products.
 - Arsenic and chromium from chemically treated lumber.

Your risk of exposure varies, depending on how often you do this type of work. To reduce your exposure to these chemicals: work in a well-ventilated area and work with approved safety equipment, such as face or dust masks that are specifically designed to filter out microscopic particles.
11. Do not operate this sander while tired or under the influence of drugs, alcohol or any medication.
12. Make certain the switch is in the **OFF** position before connecting the machine to the power supply.
13. Always sand with the grain of the wood.
14. Always feed stock against the rotation of the drum.
15. Do not sand pieces of material that are too small to be safely supported.
16. When sanding a large piece, provide additional support at table height.
17. Always connect and use a dust collector to the drum sander while operating.
18. Make certain the machine is properly grounded.
19. Make all machine adjustments or maintenance with the machine unplugged from the power source.
20. Remove adjusting keys and wrenches. Form a habit of checking to see that keys and adjusting wrenches are removed from the machine before turning it on.
21. Keep machine guards in place at all times when the machine is in use. If removed for maintenance purposes, use extreme caution and replace the guards immediately.
22. Make sure the drum sander is firmly secured to the stand or bench before use.

Warnings

23. Check damaged parts. Before further use of the machine, a guard or other part that is damaged should be carefully checked to determine that it will operate properly and perform its intended function – check for alignment of moving parts, binding of moving parts, breakage of parts, mounting, and any other conditions that may affect its operation. A guard or other part that is damaged should be properly repaired or replaced.
24. Provide for adequate space surrounding work area and non-glare, overhead lighting.
25. Keep the floor around the machine clean and free of scrap material, oil and grease.
26. Keep visitors a safe distance from the work area. **Keep children away.**
27. Make your workshop child proof with padlocks, master switches or by removing starter keys.
28. Give your work undivided attention. Looking around, carrying on a conversation and “horse-play” are careless acts that can result in serious injury.
29. Stand to one side of the conveyor and make sure no one else is standing in line with the conveyor while feeding into the machine. The drum sander operates at high speed and should a part slip, it will exit the machine at a high rate of speed and may result in injuries to anyone standing directly in front of the infeed. (Keep the conveyor belt clean and check pin-roll adjustments). Maintain a balanced stance at all times so that you do not fall or lean against the sanding drum or other moving parts. Do not overreach or use excessive force to perform any machine operation.
30. Use the right tool. Don't force a tool or attachment to do a job for which it was not designed. The right tool will do the job better and safer at the rate for which it was designed.
31. Use recommended accessories; improper accessories may be hazardous.
32. Maintain tools with care. Keep tools sharp and clean for the best and safest performance. Follow instructions for lubricating and changing accessories.
33. Never brush away sawdust while the machine is running. Use the correct speed and feed for the tool. Be sure that the tool is the correct one for your operation.
34. Never stand on a machine. Serious injury could occur if the machine tipped or if the sanding drum is unintentionally contacted.
35. Never leave the machine running unattended. Turn the power off and don't leave the machine until it comes to a complete stop.
36. All doors should be closed, all panels replaced and other safety guards should be in place before the machine is started or operated.
37. Keep your hands clear when feeding parts onto the conveyor. The part will be forced down as it begins to feed into the machine, causing a pinching action between the part and the table. Use caution! Hands should be clear of the stock and the table to avoid pinching. Never reach into a running machine. Turn off the electrical power and stop the machine before attempting to retrieve parts from within it. Keep your hands away from the sanding area. Contact with internal moving parts can result in the loss or injury to fingers, hands and arms.
38. Remove loose items and unnecessary work pieces from the area before starting the machine.

Familiarize yourself with the following safety notices used in this manual:



This means that if precautions are not heeded, it may result in minor injury and/or possible machine damage.



This means that if precautions are not heeded, it may result in serious injury or possibly even death.

- - SAVE THESE INSTRUCTIONS - -

Introduction

This manual is provided by JET covering the safe operation and maintenance procedures for a Model 10-20 Plus Drum Sander. This manual contains instructions on installation, safety precautions, general operating procedures, maintenance instructions and parts breakdown. This machine has been designed and constructed to provide years of trouble free operation if used in accordance to instructions set forth in this manual. If there are any questions or comments, please contact either your local supplier or JET. JET can also be reached at our web site: www.jettools.com.

Specifications

Model Number.....	10-20 Plus
Stock Number.....	628900
Maximum Width (in).....	20 (Two Passes)
Minimum Length (in).....	2-1/4
Maximum Thickness (in).....	3
Minimum Thickness (in).....	1/32
Drum (in).....	5 x 10 Extruded Aluminum
Drum Speed (RPM).....	1700
Dust Chute (in).....	4
Conveyor Motor.....	43 inch-lb Torque, Direct Drive, D.C.
Conveyor Variable Feed Rate (FPM).....	0-12
Motor (TEFC).....	1 HP, 1Ph, 115V only
Net Weight (lbs).....	96

The specifications in this manual are given as general information and are not binding. JET reserves the right to effect, at any time and without prior notice, changes or alterations to parts, fittings, and accessory equipment deemed necessary for any reason whatsoever.

⚠WARNING Read and understand the entire contents of this manual before attempting assembly or operation! Failure to comply may cause serious injury

Unpacking

Separate all parts from the packing material. Check each part against the *Contents of the Shipping Container* and make certain that all items are accounted for before discarding any packing material.

Report any damage to your distributor.

Contents of the Shipping Container

- 1 ea Sander Assembly (A)
- 1 ea Handwheel with Handle (B)
- 2 ea Trackers (C)
- 1 ea TUF Tool (D)
- 1 ea Abrasive Strip (wrapped on the drum)
- 1 ea Conveyor Belt (attached to the base)
- 1 ea Owner's Manual
- 1 ea Warranty Card

Hardware Bag (see Note)

- 4 ea 3/8"-16x5/8" Hex Cap Screws (E)
- 4 ea 3/8" Flat Washers (F)

Note: For attaching Sander to the optional Open Stand

Optional Accessories

Optional Accessories are listed on page 23. To purchase any of these accessories contact your dealer.

Tools Required for Assembly

- 9/16" Wrench
- No. 1 or No. 2 Cross Point Screwdriver
- 1/8" hex wrench

Assembly

10-20 Plus Sander

Attach the handwheel (B, Fig. 1) to the height adjustment screw and tighten with a 1/8" hex wrench.

Stand

1. If you purchased the optional *10-20 Stand* (A, Fig. 1), assemble it as described in the manual included with the stand.
2. Mount the 10-20 Plus Sander on the stand and secure with four 3/8"-16x5/8" Hex Cap Screws and four 3/8" Flat Washers (*Items E, F, Contents of the Shipping Carton*) and tighten with a 9/16" wrench.

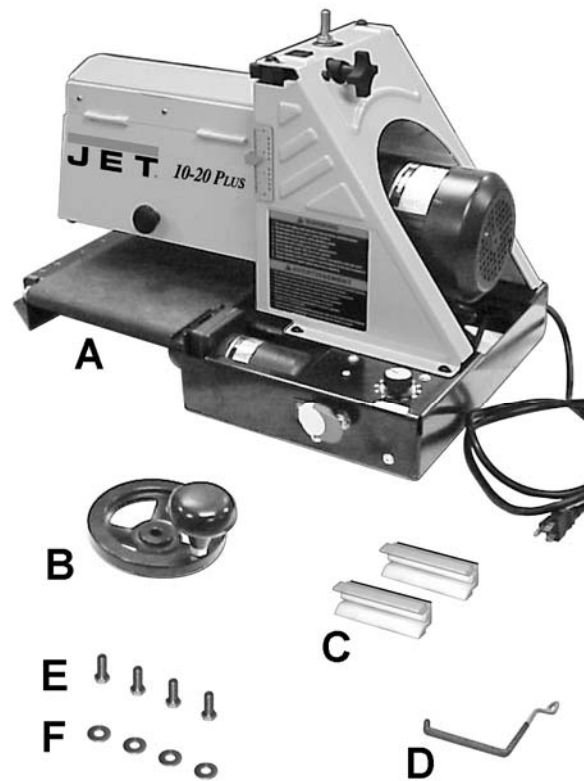

Contents of the Shipping Carton

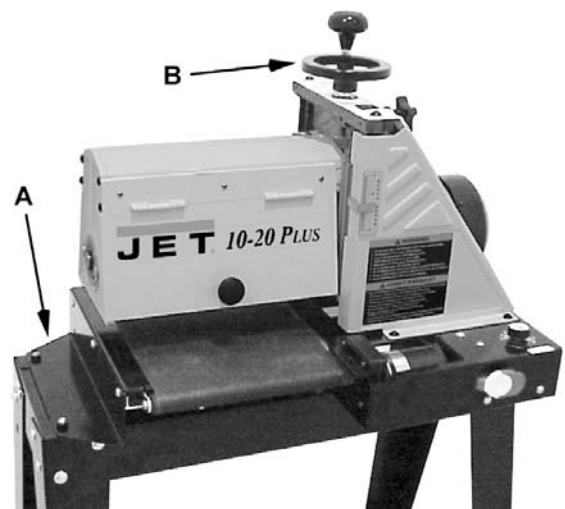

Figure 1

Installing the Trackers™

Trackers dramatically reduce tracking adjustments of the conveyor belt by guiding the belt towards the center of the rollers and by keeping the belt from running off the rollers.

The Trackers are installed on the underside of the conveyor belt as follows:

1. Disconnect the machine from the power source.
2. Raise the sanding drum to its highest position (see *Drum Height Control* on page 11).
3. Remove the tension from the conveyor belt (*Conveyor Belt Tension* on page 11).
4. Referring to Figures 2 and 3: The tracker is positioned on the underside of the conveyor belt, on the infeed side of the sander, (closest to the rubber covered drive roller and gear motor). The back of the tracker is magnetized and will stick to the sidewall of the conveyor bed. Do not install the tracker if the edge of the conveyor belt is damaged or torn.
5. When the tracker is installed, slide the conveyor belt into the bottom slot of the tracker.

Note: When installed properly, only the bottom lip of the tracker will be visible. The top slot is to be used if the bottom slot wears out.

6. When installing the second tracker, repeat steps four and five. Use both trackers unless the conveyor belt is damaged.
7. Make sure all of the switches are off. Reconnect the power to the machine.
8. *Tension the conveyor belt* (see *Conveyor Belt Tension* on page 11). With both trackers installed, it is very important to have equal tension on both sides of the conveyor belt. Tighten both sides of the adjustment screws until equal tension is obtained.
9. Turn the conveyor on full speed and carefully place both hands on the conveyor belt to check the tension. If the conveyor belt can be stopped, continue increasing the tension until the conveyor belt cannot be stopped by placing both hands on the belt while the conveyor is operating at full speed.
10. Continue to watch the tracking of the conveyor belt and adjust it only if necessary; do not allow the conveyor belt to buckle under the conveyor bed.

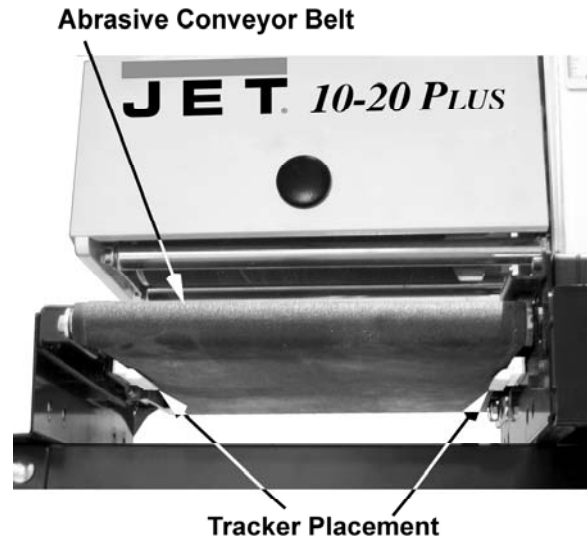

Figure 2

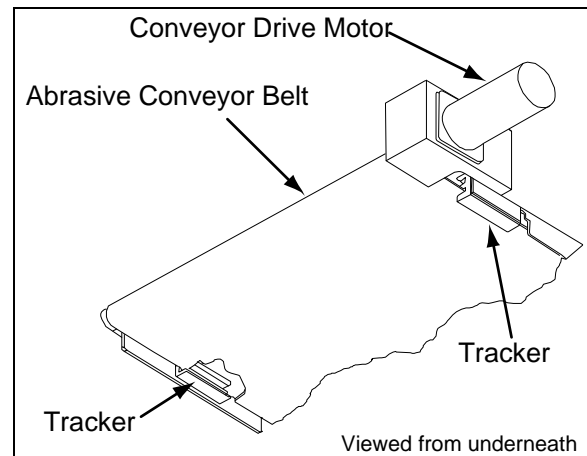

Figure 3

Electrical

Electrical Requirements

When connecting the drum sander to the power source outlet, the outlet must be properly grounded to protect the operator from electrical shock.

In the event of a malfunction or breakdown, grounding provides a path of least resistance for electrical current to reduce the risk of electrical shock. This machine is equipped with an electric cord having an equipment-grounding conductor to be inserted into an outlet that is properly installed and grounded in accordance with all local codes and ordinances.

Improper connection of the equipment grounding conductor can result in a risk of electric shock. The conductor with insulation having an outer surface that is green (with or without yellow stripes) is the equipment -grounding conductor. If repair or replacement of the electric cord or plug is necessary, do not connect the equipment-grounding conductor to a live terminal.

Plug power cord into a 110-120V properly grounded outlet protected by a 14-amp fuse or circuit breaker.

⚠ WARNING Do not touch the prongs of the power cord plug when plugging or unplugging to or from an outlet.

⚠ WARNING If improperly grounded, this power tool can cause serious injury from electrical shock, particularly when used in damp locations or near plumbing. If an electrical shock occurs, there is the potential of a secondary hazard such as your hands coming in contact involuntarily with the rotating grinder.

Electrical Connections

The model 10-20 Plus Drum Sander is rated at 115V, 1Ph. This sander is designed for use on a circuit with an outlet that looks the one shown in Fig. A, and has a grounding prong, also shown in Fig. A. A temporary adapter (Fig. B) may be used to connect the plug to a two-prong receptacle (Fig. B) if a properly grounded outlet is not available. A temporary adapter should only be used until a properly grounded outlet can be installed by a qualified electrician. **This adapter is not applicable in Canada.** The green colored lug must be fastened to the cover plate screw.

Important: The adapter illustrated in Fig. B is for use only if you already have a *properly grounded* two-prong receptacle. If you are not sure that your outlet is properly grounded, have it checked by a qualified electrician.

⚠ WARNING Before plugging into the power source, be sure that power switch is in the OFF position.

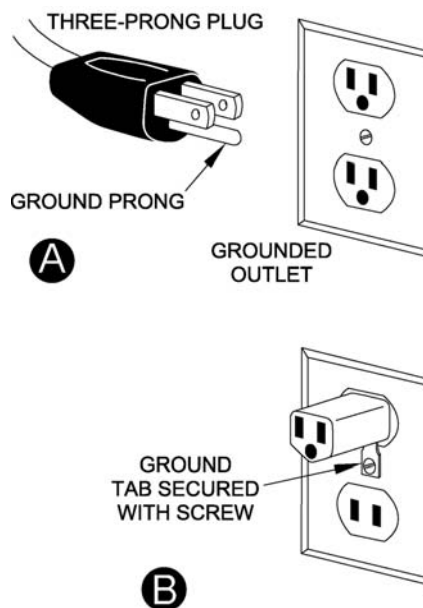

Extension Cords

Use only three-wire extension cords that have three-prong grounding type plugs and three-prong receptacles that accept the tool's plug. Replace or repair damaged or worn core immediately.

Use only UL Listed extension cords with this product.

Improper use of extension cords may cause inefficient operation of the sander that can result in overheating. Be sure the extension cord is rated to allow sufficient current flow to the motor. For the proper gauge for the sander in use, see the chart in Table 1.

Amp Rating	Volts	Total length of cord in feet			
	120V 240V	25	50	100	200
		50	100	200	300
		AWG			
0 – 05		18	16	16	14
6 – 10		18	16	14	12
10 – 12		15	16	14	12
12 – 16		14	12	not recom	not recom

Table 1

Controls

On/Off Switch

⚠WARNING Before powering up the unit, make sure all of the tools used to assemble and adjust the unit are removed and accounted for. Make sure your hands, loose clothing and any other items that may get caught are safely away from the unit.

The *On/Off Switch* (A, Fig. 4) is located on the front of the sander. To turn the sander on, pull the switch to the on position. To turn the sander off, push the switch to the off position.

Switch Lock

The sander can be locked from unauthorized use by locking the switch. To lock the switch:

1. Turn the switch to the off position and disconnect the sander from the power source.
2. Pull the *key* (C, Fig. 4) out. The switch cannot be turned on with the key removed.

IMPORTANT Should the key be removed from the switch in the on position, the switch can be turned off but cannot be turned back on.

3. To replace the key, slide the key into the slot on the switch until it snaps.

Circuit Breaker

The sander is equipped with a motor protective device (circuit breaker). The breaker will automatically shut the sander off when excessive current is consumed.

If the breaker is tripped, turn the sander off and reset the circuit breaker by pressing the *button* (B, Fig. 4).

⚠WARNING Be sure to turn the sander off before resetting the circuit breaker to avoid unintentionally starting the sander

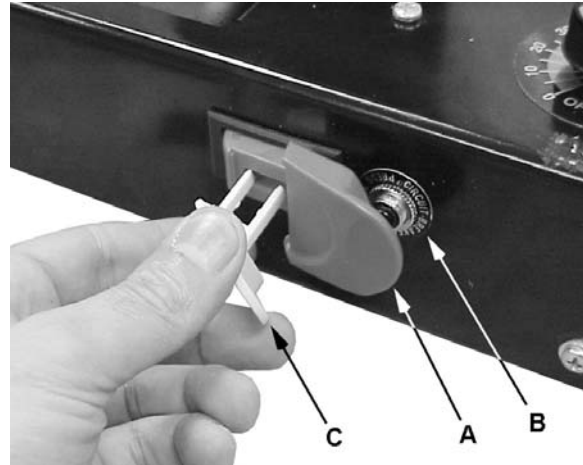

Figure 4

Adjustments

Drum Height Control

Drum height is controlled by the *height adjustment handle* (A, Fig. 5). Turning the handwheel in a counterclockwise direction lowers the drum.

Turning the height adjustment handwheel one revolution lowers the drum approximately 1/16".

Conveyor Belt Tension

CAUTION The conveyor belt is over-tensioned at the factory for shipping purposes. Re-adjust before operation to prevent damage to the machine.

If the conveyor belt can be stopped by hand pressure applied directly to the top of the conveyor bed, the belt is too loose. Insufficient belt tension will cause slippage of the conveyor belt on the drive roller during sanding operations.

Excessive belt tension can cause tracking problems and result in bent rollers, bent take-up brackets and premature conveyor belt and bushing wear.

Adjust the *hex nuts* (B, Fig.5) on both sides of the conveyor to obtain a snug, and equally tensioned, conveyor belt. Use the attached *wrenches* (C, Fig. 5) to adjust the hex nuts.

Conveyor Belt Tracking

Belt tracking adjustment may be necessary during the break-in period and normal operation to compensate for belt stretching.

Abrasive belt tension must be properly adjusted before adjusting the tracking. Adjust the belt tracking while the conveyor belt is running at its fastest speed.

Tighten the *hex nut* (B, Fig. 5) on the side the belt is drifting towards, and loosen the hex nut on the opposite side. Use the attached *wrenches* (C, Fig. 5) to adjust the hex nuts.

Note: Adjustment should be made in 1/4 turns of the hex nut. Allow time for the belt to react to the adjustment. Do not over adjust.

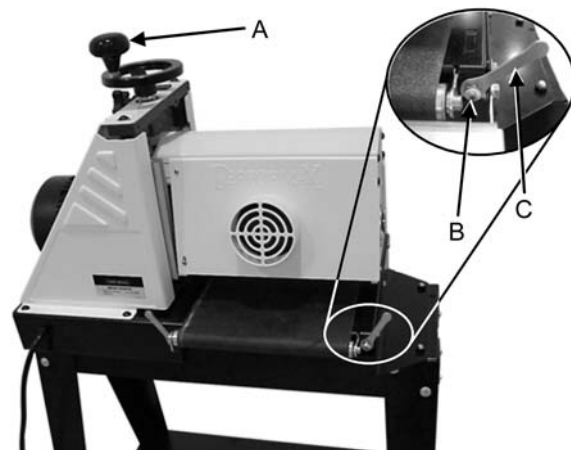

Figure 5

Drum Alignment

The sanding drum comes preset from the factory. If a problem with the drum alignment occurs, follow the instructions listed below.

Checking the Drum Alignment

1. Lift the *knob* (A, Fig. 6) to open the dust cover and remove the abrasive strip. If you are unsure how to do this, see the “Wrapping Abrasive Strips” section in this manual.
2. Using a metal straight edge, or ruler, as a thickness gauge (B, Fig. 6), insert the gauge between the drum and the conveyor bed on the outer end of the drum.
3. Open the dust cover and lower the sanding drum while slowly rotating the drum by hand until the drum lightly contacts the thickness gauge.
4. Remove the thickness gauge and place it under the drum at the opposite end. If the drum does not contact the thickness gauge to the same degree as the other end of the drum, alignment is necessary.

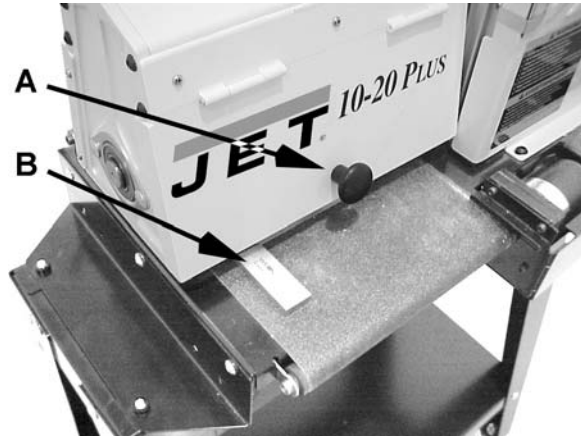

Figure 6

Aligning the Drum

1. Loosen the two *socket head button screws* (C, Fig. 7).
2. Lay the thickness gauge under the drum lengthwise.
3. Adjust the *knob*, (D, Fig. 7) until the drum contacts the gauge equally along its entire surface. Turn the adjusting knob counterclockwise to lower the outboard end of the drum, and clockwise to raise the outboard end of the drum.
4. When the drum is parallel to the conveyor, tighten the two socket head button screws.

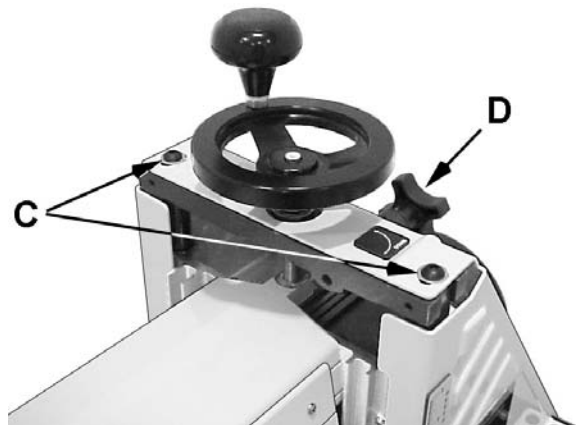

Figure 7

Fine Tuning Drum Alignment

When sanding boards wider than the drum, drum alignment is critical and must be adjusted slightly higher on the outboard end. This will prevent any ridges from developing in the stock. Always check it on a piece of scrap wood, as follows, before sanding the work piece.

Run a piece of scrap wood approximately 6” wide by 16” to 18” long through the sander sideways so that the end of the board extends past the end of the drum.

Turn the board 180 degrees and sand the same side without changing the sanding height.

If a ridge is visible where the drum overlaps, loosen the two *socket head button screws* (C, Fig. 7) and turn the *adjusting knob* (D, Fig. 7) slightly. Turn the adjusting knob clockwise to lower the outboard end of the drum and counterclockwise to raise it. Tighten the two hex cap bolts. Repeat this process until the ridge is gone and the entire board is sanded.

Wrapping Abrasive Strips

Note: When using JET “Ready to Wrap” and “Ready to Cut” abrasives, not all of the steps below are necessary. You can use the original abrasive belt that came with the sander as a template for cutting your own strips.

1. Mark and cut a taper at one end of the roll, as shown in Figure 8.
2. Square off the end of the taper, as shown in Figure 8.

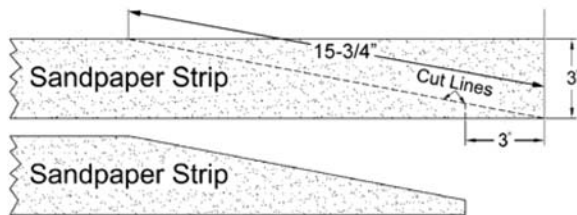

Figure 8

3. Squeeze the *fastener lever* (A, Fig. 9) on the outboard end of drum, and insert the tapered end of the *abrasive* (B, Fig. 9) so that it uses most of the width of the slot. Release the fastener lever to securely hold the strip end to the fastener.
4. The cut edge of the abrasive strip should follow the edge of the drum, as shown in Figure 9.
5. Wrap the abrasive strip around the drum, being careful not to overlap the windings, as shown in Figure 10.
6. Mark the trailing end of the strip where it crosses the inboard end of drum (C, Fig. 11).
7. Remove the abrasive strip and cut a taper as was done with the starting edge (Figure 8).

Note: The taper on the remaining roll can be used as the taper for the starting edge of the next strip to be cut.

8. Rewrap the drum starting at the left side as described in steps 3-5.
9. Squeeze the fastener lever on the inboard end of the drum, and insert the tapered end of the abrasive strip through the slot into the take-up fastener.

IMPORTANT Position the abrasive strip with sufficient room between the inside of the slot and the tapered end of the strip to allow it to be pulled into the drum as needed, (See Figure 12).

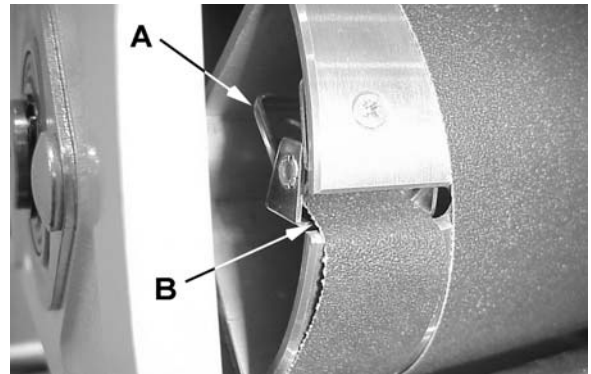

Figure 9

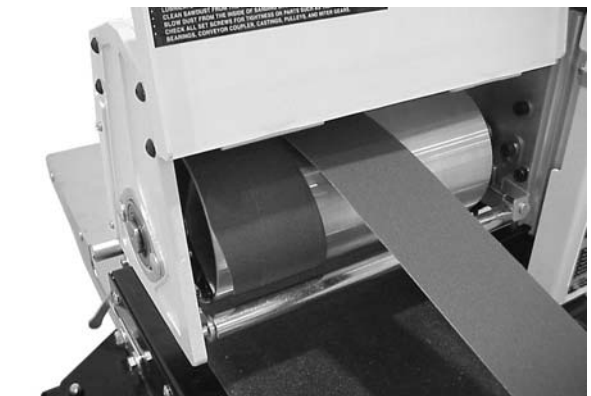

Figure 10

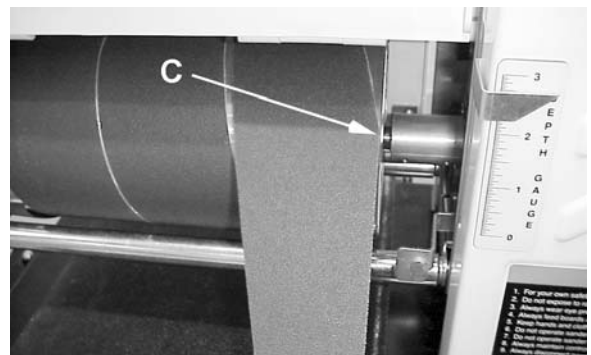

Figure 11



Figure 12

Using the TUF Tool™

The *Tuf Tool* (Figure 13) can also be used to hold the take-up fastener in place while you feed the sandpaper through the slot.

1. Clip the sandpaper into the outboard fastener. Wrap the drum, being careful not to overlap the windings. Hold the sandpaper over the inboard slot with the left hand.
2. Hold the TUF Tool with the red end of the tool pointing away from you (Figure 14). Insert the hook into the hole in the end of the take-up lever of the fastener (Figure 14).



Figure 13

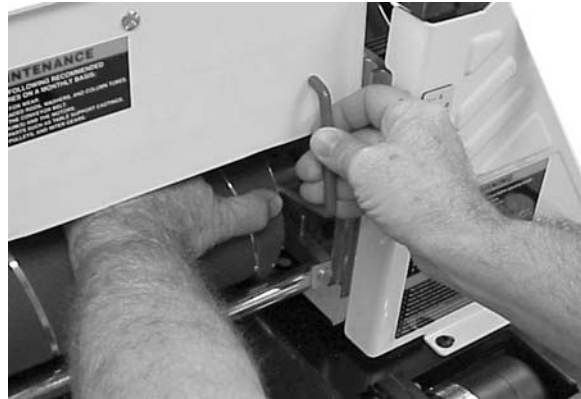

Figure 14

3. Lift the lever with the TUF Tool, pulling the lever up until it touches the inside of the drum. Turn the TUF Tool counterclockwise and lower it onto the sandpaper, making sure it is holding the sandpaper tight and opening the throat of the fastener (Figure 15).
4. Insert the tapered end of the paper into the slot and the fastener. It may be necessary to trim the tapered end of the paper so it does not "bottom out" against the inside of the drum. Be sure to leave a gap of at least 1/8" between the tapered strip and the closed end of the slot to allow the strip to be pulled into the fastener as needed (Figure 15). If necessary trim the outside edge of the paper.



Figure 15

5. Hold the sandpaper in place with your left hand. Rotate the drum toward you slightly. Pull up on the TUF Tool and turn the handle clockwise while maintaining upward pressure. Slowly move the TUF Tool away from you slightly, then down, while easing it out of the hole. This releases the lever into its proper position. (Figure 16).

All abrasive strips will stretch with use and may stretch enough to allow the take-up lever to reach its lowest position so it cannot maintain tension on the strip. If this occurs, follow the above procedures to reset the take-up lever.



Figure 16

Connecting Sander to a Dust Collector

Dust collection is necessary for all drum sanders. The JET 10-20 is equipped with a 4" *dust collection port* in the back of the dust cover, and is designed to be used with a standard dust collector as shown in Figure 17.

JET offers a variety of Dust Collectors and Air Filtration Units that will work nicely with your new sander. Contact your local distributor for more information.



Figure 17

Setting the Depth Gauge

The *depth gauge* indicates the distance from the bottom of the drum to the top of the conveyor.

1. Lower the drum, with the sandpaper installed, until it touches the conveyor.
2. Loosen the *screw* (B, Fig. 18).
3. Adjust the *pointer* (C, Fig. 18) to read zero and tighten the screw.

Note: Depending on the desired accuracy, you may need to repeat this process when installing different sandpaper grits.



Figure 18

Setting the Depth of Cut

Adjusting the JET 10-20 for proper contact between the abrasive and the stock is the most important set-up procedure before operating the sander. It may take some experimentation to determine the proper depth of cut, given the variables of abrasive grit and types of wood. For best results, use scrap wood to practice sanding and to develop your skills and familiarity with the machine before doing any finish work.

A good rule of thumb when sanding with grits finer than 80 is lower the drum so that it contacts the work piece but can still be rotated by hand. When using grits coarser than 80 grit, you can lower the drum slightly more. However, a combination of several variables will determine the proper depth of cut to use, including the following:

- Abrasive type and grit size.
- Width of the piece being sanded.
- Hardness of the piece being sanded.
- Feed rate of the piece being sanded.

Establishing the Proper Drum Height

To establish the proper drum height, place the board to be sanded under the drum and lower the drum until it just touches the board. **Note:** The sanding drum should still rotate by hand. Without changing the drum height, finish feeding the stock under the sander. Start the sanding drum and sand the board at that same position.

Abrasives

Overview

The abrasive material you choose will have a substantial effect on the performance of your sander. Variations in paper type, weight, coating and durability all contribute to achieving your desired finish. For the best sanding results, JET offers premium abrasives that have been tested and certified for lowest overall cost and maximum performance. Genuine JET abrasives are available in pre-cut "Ready-to-Wrap" lengths or in the convenient pre-marked "Ready-to-Cut" box. These items are listed in the *Optional Accessories* section on page 23.

Selecting Drum Abrasives

To achieve maximum sanding results, it is important to select the proper grit of abrasive for the type of sanding being performed. As with any sanding operation, first begin sanding with a coarser grit, depending on the roughness of the stock, or the amount of stock to be removed. Then progressively work toward finer grits. The chart below shows the general uses for the various grits. JET offers strip rolls in most of the different abrasive grits shown.

Grit	Common Applications
24	Abrasive planing, surfacing rough-sawn boards, maximum stock removal, glue removal.
36	Abrasive planing, surfacing rough sawn boards, maximum stock removal, glue removal.
60	Surfacing and dimensioning boards, truing warped boards
80	Surfacing, light dimensioning, removing planer ripples.
100	Light surfacing, removing light planer ripples.
120	Light surfacing, minimal stock removal.
150	Finish sanding, minimal stock removal.
180	Finish sanding only, not for stock removal.
220	Finish sanding only, not for stock removal.

Selecting Abrasive Grits

The amount of stock to be removed is a major consideration when choosing the grit grade to start with. Grits of 24, 36, 50, 60 and 80 are primarily designed for stock removal. Grits of 24 and 36 will remove the most material in one pass, whether you are doing abrasive planing, cleaning up glued panels or flattening stock. Grits from 100 through 220 are primarily finishing grits designed to remove the scratch pattern from the previous grit used. For best results, never skip more than one grit grade when progressing through a sanding sequence.

For fine work, such as furniture, try not to skip any grit grades during the sanding process. In general, premium quality abrasives such as genuine JET abrasives will produce a better finish with a less noticeable scratch pattern. **Note:** Grits that are too fine can sometimes burnish the wood and leave a glossy surface that will not accept stains evenly. This will vary by the type of wood. Oak, for example, is susceptible to burnishing because of its open pores.

Cleaning Abrasive Strips

A sandpaper cleaning stick may be used to remove deposits and help extend sandpaper life. To use, operate the sanding drum with the dust cover open.

CAUTION For your own safety, always wear eye protection while performing sandpaper cleaning.

Take all precautions to avoid any contact of hands or clothing with uncovered drums. Hold the cleaning stick against the rotating drum and move it along the drum surface. It is a good idea to use a shop brush or air nozzle to remove any cleaning stick crumbs from the drums before resuming sanding operations.

Cloth-backed abrasives can be cleaned by soaking in paint thinner or mineral spirits for 20 minutes to one hour. Then use a nylon brush to remove any buildup.

Stretching Abrasive Life

Abrasive life can also be increased by removing the abrasive strip from the drum and reversing it. To do this, remove the strip and use what was the trailing end as the starting end on the left (outboard) side of the drum. Reversing the strip will provide a fresh set of cutting edges on the drum.

Stock Feeding Angle

The optimum stock feeding angle, when sanding, is at a 60-degree angle. However, even a slight stock feeding angle will provide more effective stock removal, less loading of abrasives, longer abrasive life, potentially faster feed rates and reduced motor loads.

When finish sanding, the work piece should be fed through in line with the grain on the final one or two passes for the optimum finish.

Multiple-Piece Sanding Runs

When abrasive planing (or thickness sanding) a run of similar pieces that you want to have the same thickness, it is best to sand all the pieces at the same time. This way you will be able to determine the thickness of the thinnest piece and process all pieces to that same thickness. Be aware that the sander will remove cups and crowns in the work piece; consider this when measuring the processing stock to the same thickness.

Edge Sanding

When edge sanding, the JET sander will mimic the opposite edge of the stock which is lying on the conveyor belt. Because of this, it is important for the stock edge to have been ripped at the proper angle to the face before the sanding process. When edge sanding stock that is less than 3/4" wide, or more than 2" high, it is good procedure to stack and clamp several pieces together to prevent them from slipping, or tipping.

Sanding Imperfect Stock

When sanding stock with a cup or crown, place the crown up. This will stabilize the stock to help prevent tipping or rocking during sanding. (After the crown has been removed and the top is flat, turn the stock over and sand the opposite side.) To avoid personal injury, take special care when sanding stock that is twisted, bowed or otherwise varies in thickness from end to end. If possible, support such stock as it is being sanded to keep it from slipping, or tipping. Use extra roller stands, help from another person, or hand pressure on the stock to minimize potentially hazardous situations.

Face Frames and Raised Panel Doors

It is very important to have the proper abrasive contact when doing this type of sanding. If the sander is set to take an excessive depth of cut, the result can be a gouge, or dip as the drum goes from sanding the rails at full width to

sanding just a few inches of width on the stiles. To prevent this problem, make sure that when using abrasives finer than 80 grit, the drum is in contact with the wood but can still be spun by hand.

Maintenance

For best results, perform the following recommended maintenance procedures on a monthly basis:

- Lubricate the conveyor bushings and check for wear.
- Lubricate all moving parts, such as threaded rods, washers and bushings.
- Clean the sawdust from the conveyor belt and sanding drum.
- Blow the dust from the motors and switches. Blow the dust from the inside of the sanding drum to prevent vibration. Be careful not to disturb the drum balancing weights.
- Check all the setscrews for tightness on parts such as bearings, the conveyor and couplings.

Conveyor Belt Replacement

To replace the conveyor belt:

1. Disconnect the machine from the power source.
2. Raise the drum to its highest position using the *handwheel* (A, Fig. 19).
3. Remove the belt tension by loosening both *take-up nuts* (B, Fig. 19).
4. Unscrew the three *screws* (D, Fig. 19) that attach the conveyor to the bracket.
5. Unbolt the two *hex head screws* (C, Fig. 19) that hold the bracket to the bench or stand.
6. Slide the conveyor belt off the conveyor and replace it with a new belt.
7. Reverse the procedure for installation.

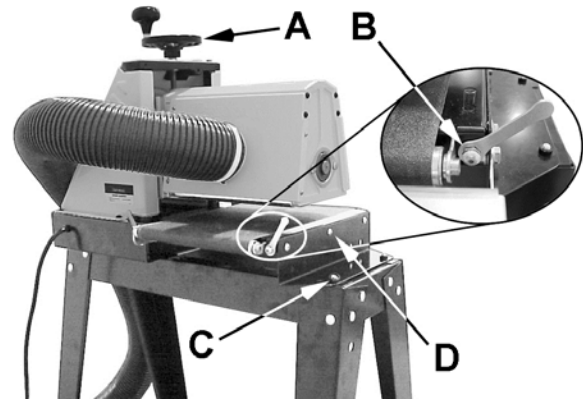

Figure 19

Tension Roller Alignment

1. Remove the *abrasive strip* (E, Fig. 20) from the drum.
2. Loosen the two bearing *hex nuts* (F, Fig. 20) on the outboard side of the drum and two *cap screws* on the inboard side (G, Fig. 20).
3. This will allow the tension rollers to drop to their lowest position.
4. Lower the sanding drum so that it just touches the conveyor bed.
5. Turn the drum height handle one complete revolution to raise the drum.
6. Retighten the bearing hex nuts and the cap screws.

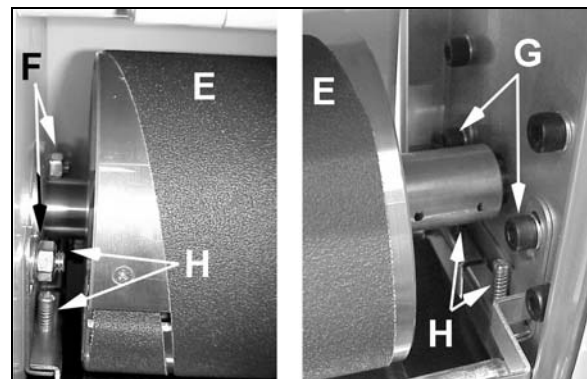

Figure 20

Tension Roller Pressure Adjustment

You can also adjust the spring-loaded screws (H, Fig. 20), found on the pressure roller brackets, to increase or decrease roller pressure. If you are getting snipe marks at the leading end of the board adjust the outfeed roller pressure. If the snipe marks occur on the trailing end of the board, adjust the infeed roller pressure.

Drum Height Control Adjustment

If the height control mechanism does not operate easily or smoothly, or there is excessive vertical movement of the drum carriage, perform the following adjustments.

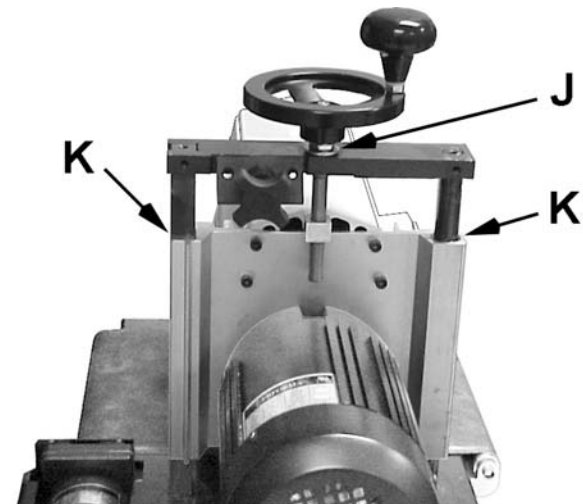

Figure 21

1. To reduce the handwheel backlash, tighten the *locknut* on the height adjustment screw (J, Fig. 21).
2. Thoroughly lubricate all mating surfaces (K, Fig. 21) and height adjustment screw.

Troubleshooting

Problem	Possible Cause	Solution
Conveyor belt does not move.	Shaft coupler is not attached.	Attach the shaft coupler.
Conveyor rollers run intermittently.	Shaft coupling is loose.	Align the shaft flats of the gear motor and the drive roller and tighten the shaft-coupling setscrews.
Abrasive strip comes off drum.	Slack in abrasive strip on drum. Abrasive improperly wrapped.	Remove the slack in the strip. Read the section on wrapping abrasive strips.
Abrasive strip is loose.	Strip caught on inside edge of slot, or on inboard side of drum. Strip not cut properly.	Re-adjust the strip end in the slot and/or trim the abrasive edge. Re-cut and re-install the abrasive strip.
Abrasive loads up prematurely.	Excessive depth of cut. Excessive feed rate. Inadequate dust collection. Inadequate abrasive.	Reduce the depth of cut. Use a slower feed rate. Increase airflow at the dust ports. Use an open-coat abrasive.
Line or groove in stock.	Inconsistent feed rate.	Do not stop or change the feed rate.
Wood burns.	Abrasive strip is overlapped. Excessive depth of cut. Excessive depth of cut for fine grit. Feed rate is too slow. Abrasive is loaded. Worn abrasives.	Re-wrap the abrasive strip. Reduce the depth of cut. Use a coarser grit or reduce the depth of cut. Increase the feed rate. Clean the abrasives. Replace the abrasives.
Board slips on conveyor belt.	Tension rollers are too high. Excessive feed rate. Dirty or worn conveyor belt.	Lower the tension rollers. Reduce the feed rate. Replace the conveyor belt.
Sander motor slows or stalls	Improper conveyor belt tension. Excessive depth of cut. Excessive feed rate.	Adjust the belt tension. Reduce the depth of cut. Reduce the feed rate.
Rippled sanded surface Non-uniformly paced ripples. Uniformly spaced ripples.	Uneven feed rate. Conveyor bed flexing or vibration.	Conveyor belt slipping, see above. Board slips on conveyor, see above. Power feed gear motor stalls, see above. Reduce the depth of cut. Reduce the feed rate. Check for loose bolts, shaft-coupling setscrews or out of balance drum.
Gouging of the wood.	Inconsistent feed rate. Stock slipping on conveyor. Work piece not properly supported.	Maintain constant feed rate (by hand). Excessive depth of cut (PowerFeed) or inadequate hold down pressure. Add work supports for long work pieces.
Snipes	Improper tension on rollers	See tension roller adjustment.
Motor overload protector trips or shop wiring breaker trips.	Excessive load on sanding drum and motor. Too many tools on circuit. Excessive length or inadequate size extension cord.	Allow motor to cool and reset overload button. Have a certified electrician correct the shop-wiring problem. Use a shorter, heavier gauge extension cord.

Parts

Parts List

Index No	Part No	Description	Size	Qty
1	1020-101	Handwheel, Height Adjustment		1
2	1020-102	Socket Head Button Screw	5/16-18UNCx3/4	2
3	TS-0680031	Flat Washer	5/16	8
4	1020-104	Main Support		1
5	1020-105	Lock Nut	1/2-20UNF	1
6	TS-0680061	Flat Washer	1/2	1
7	1020-107	Nylon Washer		1
8	1020-108	Washer, Oilite		1
9	TS-0267051	Set Screw	1/4-20UNCx1/2	2
10	1020-110	Bracket, Drum Height Control		1
11	1020-111	Height Adjusting Screw		1
12	1020-112	Bushing, Oilite		2
13	1020-113	Slide Plate, Motor Mount		1
14	1020-114	Arm		1
15	TS-081B03	Pan Head Machine Screw	#8-32UNCx1/2	7
16	1020-116	Dust Cover		1
17	1020-117	Plate, Outboard		1
18	1020-118	Hex Socket Round Head Screw	1/4-20UNCx3/4	4
19	TS-0720071	Lock Washer	1/4	4
20	50-3089	Bearing Assembly, Drum		1
21	TS-0152011	Bolt, Carriage Head	5/16-18UNCx1	2
22	TS-0561021	Hex Nut	5/16-18UNC	2
23	60-0310-P	Conveyor Belt		1
24	20-0778	Retaining Ring	STW25	1
25	1020-125	Drum		1
26	1020-126	Main Coupler		1
27	1020-127	Socket Head Cap Screw	#8-32UNCx3/8	2
28	TS-0208041	Socket Head Cap Screw	5/16-18UNCx3/4	4
29	TS-0720081	Lock Washer	5/16	6
30	10-4008-16	Screw, Fillister Head-Phillip	#8-32UNCx1	4
31	20-3211	Spring, Tension Rollers		4
32	40-0304	Bracket, Tension Rollers		1
33	40-0308-01	Bracket, Right Tension Roller Suspension		2
34	40-0308-02	Bracket, Left Tension Roller Suspension		2
35	80-1060	Pad, Bracket-Tension Roller		2
36	1020-136	Roller, Tension		2
37	TS-0208021	Socket Head Cap Screw	5/16-18UNCx1/2	2
38	1020-138	Motor Cord		1
39	1020-139	Bracket, Inboard Tension Roller		1
40	1020-140	Rod, Side Plate		1
41	1020-141	Rod, Square-Slide Plate		1
42	1020-142	Conveyor adjusting screw		2
43	1020-143	Bracket, Right Take-Up		1
44	50-3105	Bushing, Oilite		7
45	1020-145	Driven Roller		1
46	1020-146	Bracket, Left Take-Up		1
47	TS-0733041	Lock Washer, External Tooth	1/4	4
48	TS-0561011	Hex Nut	1/4-20UNC	6
49	TS-0813021	Screw	1/4-20UNCx3/8	3
50	1020-150	Foot Plate		1
51	1020-151	Drive Roller Support		1
52	1020-152	Drive Roller		1
53	10-4010-04	Set Screw	#10-32UNFx1/4	1
54	1020-154	Guide Plate		1

Parts List

Index No	Part No	Description	Size	Qty
55	10-4010-08	Socket Head Cap Screw	#10-32UNFx1/2	4
56	3237359	Conveyer Gear Motor		1
57	1020-157	Cover, Base-Control Housing		1
58	JSG96-135	Switch, On/Off-Drum		1
58A	JSG96-135A	Key for Switch (not shown)		1
59	1020-159	Overload		1
60	1020-160	Pan Head Machine Screw	#10-32UNFx1/2	5
61	12-9001	Lock Nut	#6-32UNC	2
62	72-6101	Strain Relief, DC-Motor Cord	6N-4	1
63	1020-163	Base Assembly		1
64	73-1255	Controller, Conveyer-Variable Speed		1
65	80-3137	Knob, Dust Cover		1
66	1020-166	Dust Hood, Door		1
67	20-0775	Hinge Pin		2
68	1020-168	Dust Hood, Hinge		1
69	1020-169	Needle, Depth Gauge		1
70	1020-170	Round Head Machine Screw	#10-24UNCx3/8	1
71	20-0762-02	Key	3/16SQx3/4"	2
72	1020-172	Main Drum Motor		1
73	1020-173	Spring		1
74	1020-174	Adjustment Bracket		1
75	1020-175	Socket Head Button Screw	5/16-24UNFx1/2	4
76	1020-176	Power Cord		1
77	1020-177	Strain Relief, Power Cord and Motor Cord	6N3-4	2
78	94-1670	Label, Depth Gauge		1
79	1020-179	Socket Head Button Screw	5/16-18UNCx1/2	2
80	21-1173	Fastener, Abrasive-Outboard		1
81	1020-181	Knob, Adjusting		1
82	TS-0207041	Socket Head Cap Screw	1/4-20UNCx3/4	4
83	1020-183	Label, Height-Direction		1
84	1020-184	Set Screw	1/4-20UNCx1/4	2
85	80-3131	Knob, 2 pc Swivel Handle		1
86	40-0260	Wrench		2
87	90-0080	Tracker Kit (2 pieces per box)		1
88	1020-188	Shoulder Screw		2
89	TS-0733061	Lock Washer, External Tooth	3/8	2
90	10-4009-06	Flat Head-Machine Screw	#6-32UNCx3/8	2
91	1020-191	Strain Relief	6P3-4	1
92	21-1172	Fastener, Abrasive-Inboard		1
93	TS-0680042	Flat Washer	3/8	6
94	1020-194	Machine Screw	1/4-20UNCx5/8	1
95	TS-0680011	Flat Washer	3/16	4
96	1020-196	Hex Head Screw	3/8-16UNCx5/8	4

Assembly Drawing

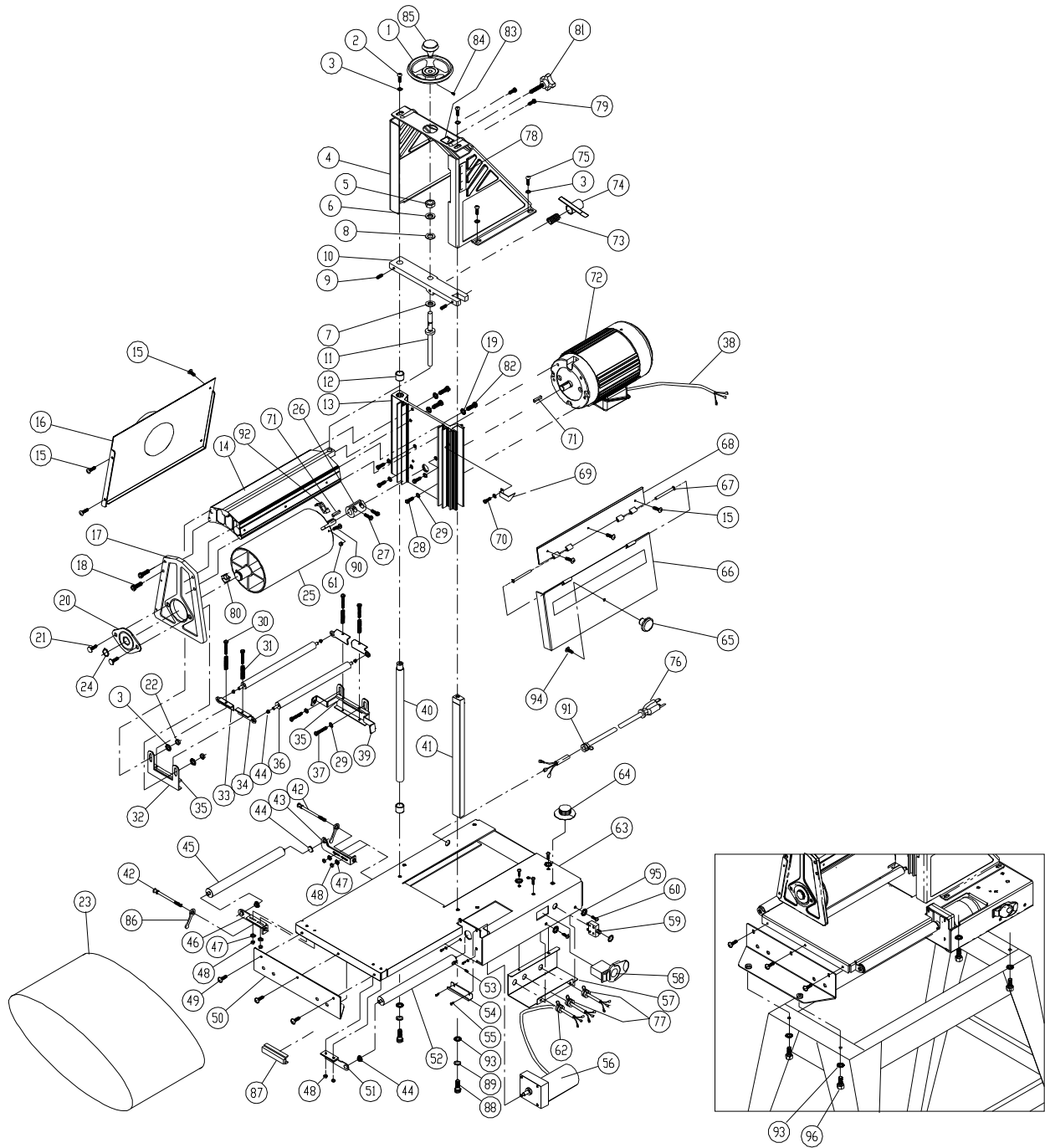

Optional Accessories

JET 10-20 Sander Accessories

Stock #	Description
638004	Open Stand with Shelf for 10-20 Plus and 16-32 Plus Sanders
98-0130	Caster Set (4) for Open Stand

JET 10-20 Abrasives

Ready-to-Wrap

Each "Ready-to-Wrap" grit contains six pre-cut wraps.

Stock No	Description	Stock No	Description
60-1060	60 Grit	60-1150	150 Grit
60-1080	80 Grit	60-1180	180 Grit
60-1100	100 Grit	60-1220	220 Grit
60-1120	120 Grit		

Ready-to-Cut (Aluminum oxide)

Stock No	Description	Stock No	Description
60-9036	36 Grit	60-9120	120 Grit
60-9060	60 Grit	60-9150	150 Grit
60-9080	80 Grit	60-9180	180 Grit
60-9100	100 Grit	60-9220	220 Grit

Wiring Diagram

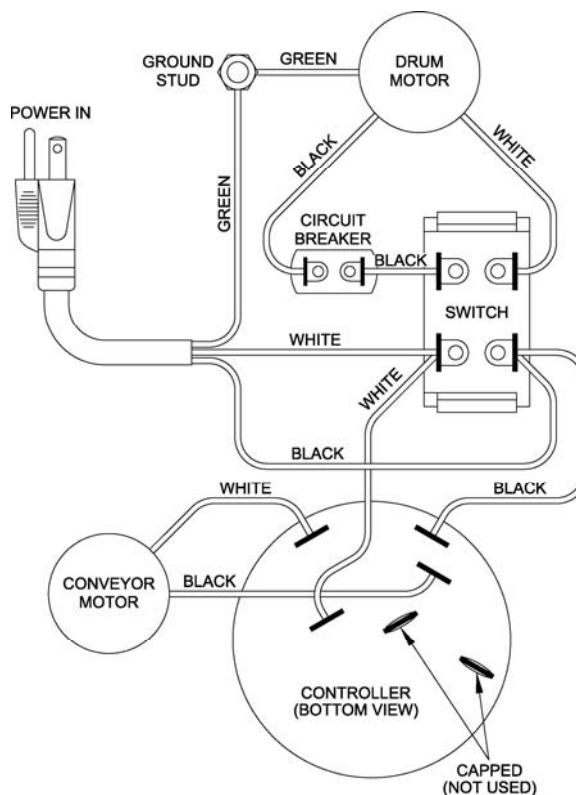

Replacement Parts

To order parts or reach our service department, call 800-274-6848 (CST), Monday through Friday (see our website for business hours, jettools.com). Having the Model Number and Serial Number of your machine available when you call will allow us to serve you quickly and accurately.



427 New Sanford Road
LaVergne, Tennessee 37086
Phone: 800-274-6848
www.jettools.com